



## **DENALI Plow Mount MA11718 Honda Pioneer**

Thank you for purchasing our DENALI plow mount. You now own a premium custom plow mount to allow you to use your plow with your SxS. Please note the following instructions and heed all warnings.

- Your UTV/SxS and/or plow system can cause death or injury, please use caution and common sense when operating your unit.
- Read your Plow Operator Manual, your Winch Operator Manual, and all warning labels before operating your UTV/SxS.
- Operate your UTV/SxS at a walking speed with the blade installed. Do not exceed 5 mph (8 km/h), even with the blade up.
- Do not operate the UTV/SxS on slopes greater than 10 degrees with the plow installed.
- Always lower the plow to the down position before leaving your UTV/SxS unattended.

**SEVERE INJURY OR DEATH MAY RESULT IF YOU ARE NEGLIGENT.**

Please verify that all hardware and parts are included in your package.

**Kit Contents:**

Item	Qty	Description
1	1	MA11718 Plow Mount
2	2	Rear Buckles
3	4	3/8" x 1 1/4" Carriage Bolt
4	4	3/8" Nylock Nut
5	4	3/8" Flat Washer
6	2	M10-1.25 x 30mm G8.8 HH Bolt
7	2	M10 Flat Washers

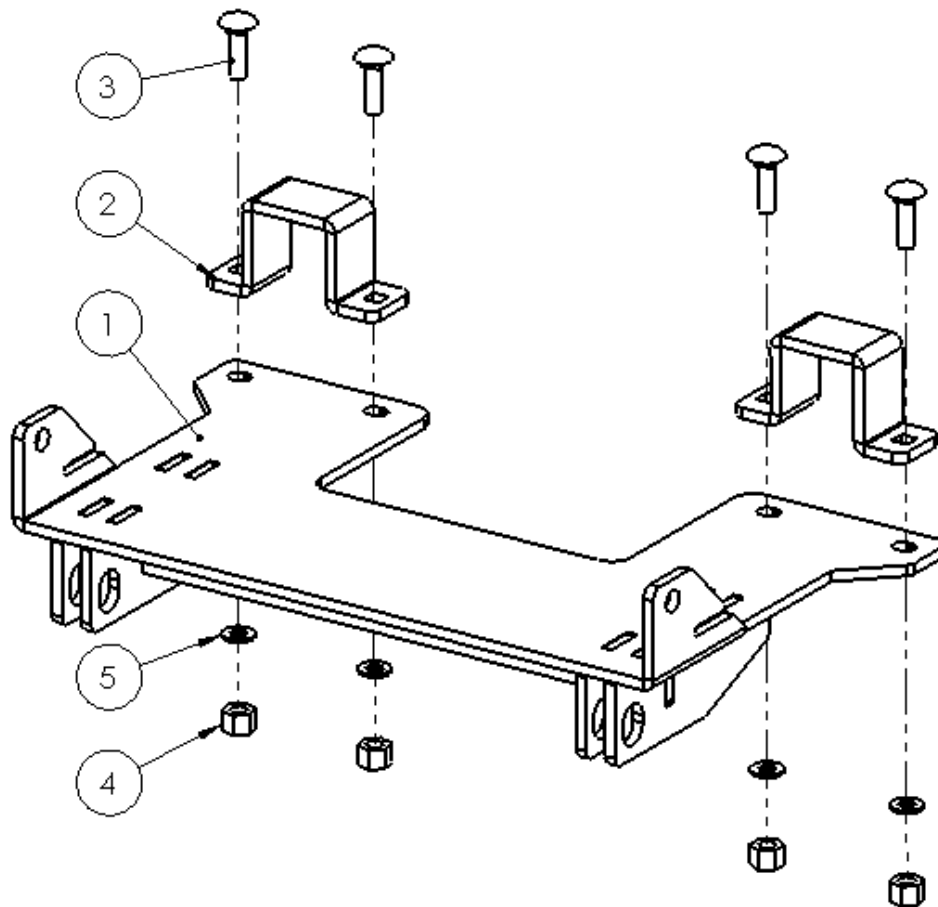

**Figure 1**

**Honda Pioneer Installation Instructions**

1. Begin by removing the two lower bolts on either side of the front bumper as shown in Figure 2. Set them aside for further use.



**Figure 2**

2. Slide the MA11718 Plow Mount over the sheet metal tabs on the front of the Pioneer as shown in Figure 3. The mount will hold itself to the frame of the Pioneer. Reinstall the bolts removed in the previous step. Some versions of the 700 Pioneer have shorter stock bolts, in this case, use the M10-1.25x30mm Hex Bolts included in the mount plate hardware kit. Due to manufacturing variations in the bumper it may be necessary to use one or two of the included M10 flat washers as spacers between the bumper and the plow mounting plate.



**Figure 3**

## Honda Pioneer MA11718



22000 Industrial Blvd  
Rogers, MN 55374  
866.527.7637

3. Slide the Rear Brackets over the Honda Pioneer frame such that the holes in the brackets line up with the holes in the bottom of the main mount plate.
4. Insert a 3/8" Carriage Bolt from the top of the Rear Bracket and on bolt of the outer most holes of the two Rear Brackets. These bolts should pass through the Main Mount plate, align the Rear Brackets if they do not meet. Secure these bolts using the 3/8" Washers and Nylock Nuts.
5. Using a 3/8" drill bit, use the inner most holes of the Main Mount plate, located under the Rear Brackets, to drill a through hole into the plastic underbody. Insert the remaining 3/8" Carriage Bolts from above and pass them through the newly drilled holes in the plastic. Secure the brackets using the 3/8" Washers and Nylock Nuts. Verify all the bolts are tightly fasten. Attach your DENALI Plow System per the instructions included in your Plow Kit.

